

GRAYSTON ENGINEERING LIMITED

115 Roebuck Road • Chessington • Surrey KT9 1JZ • UK
 Telephone: 020 8974 1122 Fax: 020 8974 2288

CARSUPPORT

STANDARD
31B02

HEAVY DUTY
31B02H

CITROËN Visa C15
PEUGEOT 305 Break

84-
78-88

EPARTS (x2)

- (1) auxiliary spring
- (2) upper seat
- (3) lower spring seat
- (4) nut
- (5) buffer

(A) original bump stop

INSTRUCTIONS

1. Jack up car so that rear wheels are off the ground.
2. Visa C15:
Remove original bumpseat from the suspension arm (not to be re-installed).
- PEUGEOT 305 Break:
Drill a ϕ 8 mm hole in bumpseat of the suspension arm. See fig. 2.
3. Mount lower spring seat(3) with nut(4) on suspension arm.
4. Insert upper seat(2) and auxiliary spring(1) over the original bump stop(A).
Compress spring(1) with buffer(5) at the bottom and guide it over seat(3).
5. Check / adjust load adjusting brake valve as per manufacturer's manual.

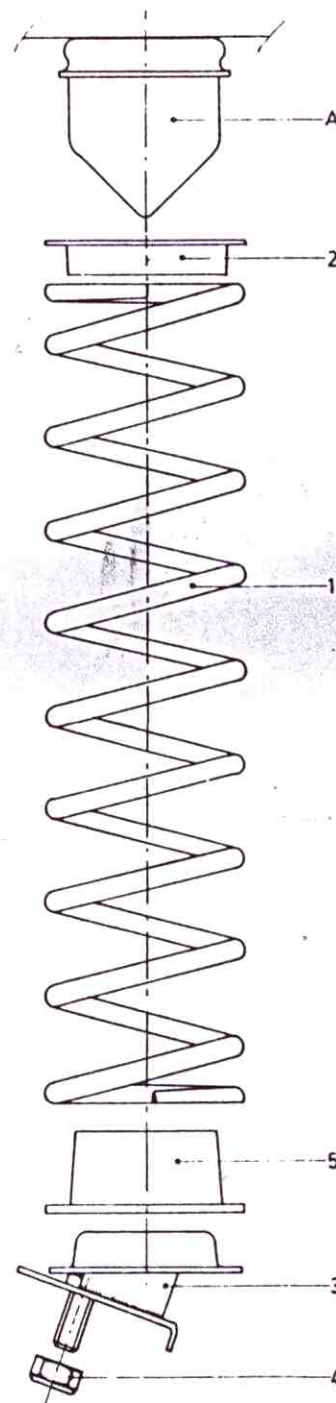

FIG. 2 Only PEUGEOT 305 Break

Right top view

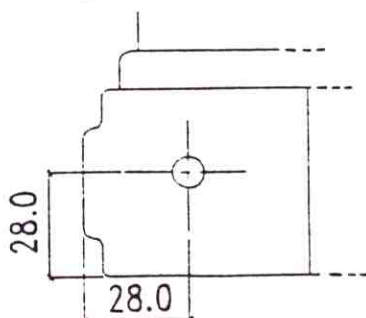

FIG. 1